

## Circuit of the Future: Interoperability and SCE's DER Program

Stephanie L. Hamilton, Manager,  
Charles K. Vartanian<sup>(\*)</sup>, Michael E. Johnson Jr.

Distributed Energy Resources, Southern California Edison  
Southern California Edison TDBU  
1000 Potrero Grande,  
Monterey Park, CA 91755  
<sup>(\*)</sup>(323) 889-5516, [charles.vartanian@sce.com](mailto:charles.vartanian@sce.com)

Ali Feliachi, Karl Schoder

West Virginia University  
Advanced Power and Electricity  
Research Center  
Morgantown, WV 26506-6109  
[alfeliachi@mail.wvu.edu](mailto:alfeliachi@mail.wvu.edu)

Paul Hines

Research and Development  
Solutions, National Energy  
Technology Laboratory  
Morgantown, WV 26505  
[Paul.Hines@sa.netl.doe.gov](mailto:Paul.Hines@sa.netl.doe.gov)

**Abstract** — This paper describes the concept of improving operation of a distribution circuit of the future through installation of interoperable devices, including distributed energy resources (DER) that are controlled using a multi-agent system approach. This concept for improving distribution service is being considered by SCE's DER Program, with additional assistance from West Virginia University in the development of a conceptual implementation methodology that includes multi-agent control.

**Key words** — circuit of the future, DER, control agents

### Introduction

Southern California Edison (SCE) is actively assessing how to maximize the potential grid benefits from Distributed Energy Resource (DER) technologies. Examples of potential grid benefits from DER include: dynamic reactive support of distribution system voltage and participation in circuit emergency reconfiguration for service restoration. To realize the full potential of DER to support and enhance our electric delivery system, understanding and enabling interoperability between DER, local distribution, and the wider grid are essential. This paper describes SCE's Circuit of the Future Project and its applicability in advancing our industry's insight into this critical issue. SCE participates as a member of DOE's Grid-Wise™ Architecture Council (GWAC) and seeks ways within SCE to embrace and make use of GWAC's interoperability principles.

From a utility perspective, the viability of DER increases as the technology matures and more "value-added" features are incorporated. As technically desirable features are added at the DER device level, accessing these features for wider grid benefit will require well thought out and effective implementation of systems and operating practices that facilitate interoperability between and across integrated electricity delivery systems. SCE's distribution Circuit of the Future project is our effort to increase our understanding of how to implement and leverage DER-Grid interoperability.

SCE's Circuit of the Future is a planned 12 kV distribution circuit that will supply customers within our service territory. In addition to our core need to build the circuit to serve customer load, SCE is taking the opportunity to do a variety of collaborative research projects to deploy and test advanced distribution devices on the Circuit of the Future, and to de-

ploy and test advanced operating and control concepts enabled through these devices on the Circuit of the Future.

The advanced device systems being deployed on SCE's Circuit of the Future include:

- Circuit level fault current limiters,
- IED-ready protective system relays,
- Circuit fault interrupters,
- Fiber optic communications backbone,
- GPS time stamping at circuit sensing/recording devices,
- Duct bank temperature monitoring,
- D-FACTS for dynamic VAR compensation and voltage support.

The operational scenarios to be tested on the physical circuit will result in an incremental advance from current present operating practices. For example, the tested scenarios are expected to produce tighter isolation of faulted circuit sections and quicker restoration of recoverable customer load. But, the operating paradigm will not be significantly altered since SCE will still use centrally decided and dispatched circuit configuration changes on the physical Circuit of the Future. More innovative operating paradigms will be explored through modeling and simulation of a virtual Circuit of the Future. Several DoE funded research projects are using the Circuit of the Future as their model for testing next-generation advanced distribution concepts. These projects that are using the Circuit of the Future as a model include West Virginia University's DoE-sponsored project "Integrated Control of Next Generation Power Systems", which is investigating application of smart agent technology in a utility operating environment. Simulation will be used to assess potential impacts from smart agents participating in circuit reconfiguration for energy management and load restoration, and for control of reactive (VAR) devices. SCE has extensive experience in electrical system planning and operation, from the bulk transmission system down to the customer meter. This experience, and our understanding of the complete delivery chain, will help maximize the benefits to be realized from interoperability of emerging DER technologies.

Two illustrative case studies are presented using load flow studies to quantify the electrical distribution system impact of two conceptually advanced distribution system scenarios. The two scenarios are "DER, D-FACTS and Voltage Support", and "DER and Reconfiguration for Load Restoration".

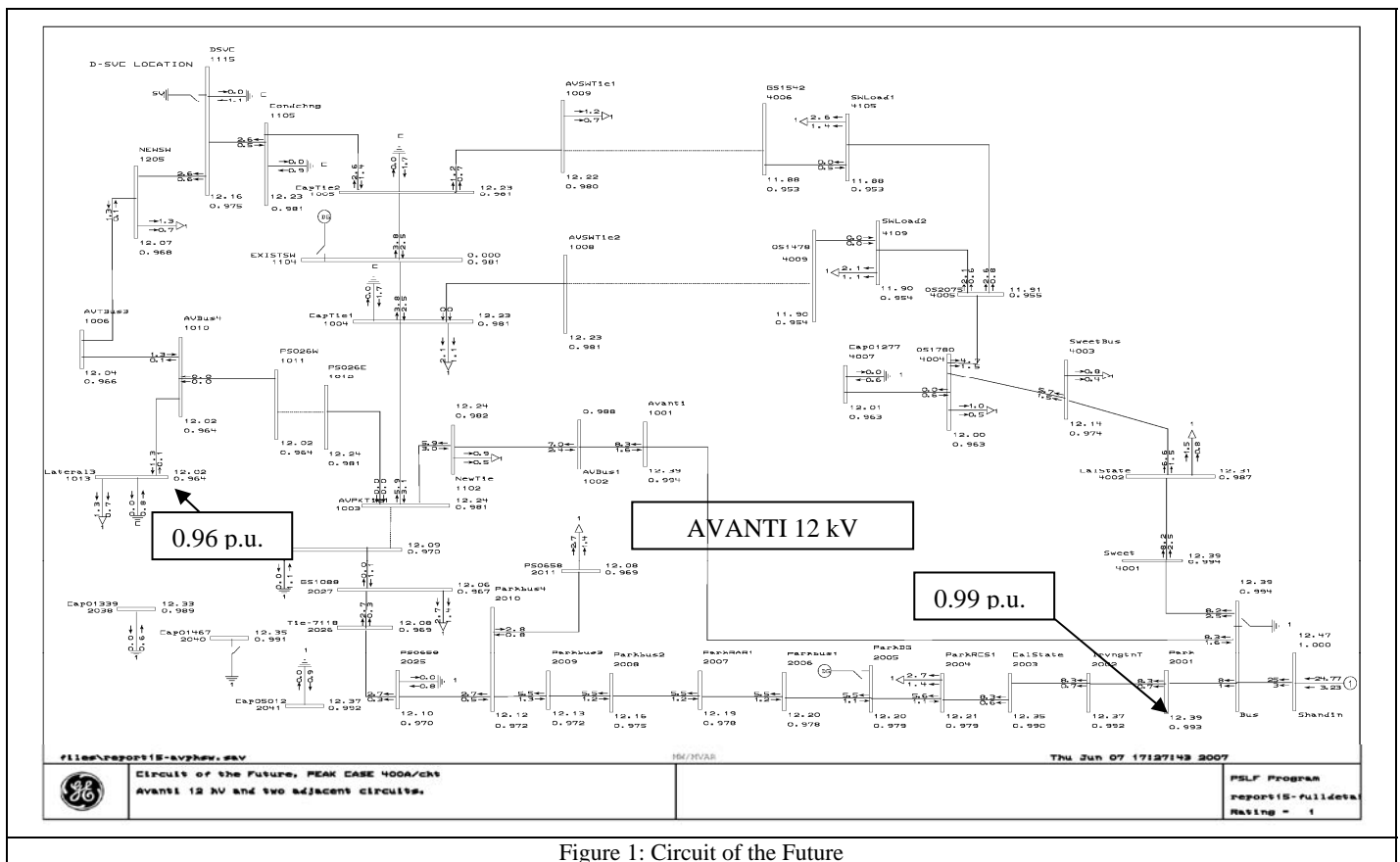

Figure 1: Circuit of the Future

Use of multi-agent systems to enable advanced distribution system functionality follows the case studies. The paper concludes with a conceptual level discussion of the potential for significant industry-wide benefits through enabling and leveraging interoperability.

struction drawings. By using this process all of the circuit's lengths and impedances were determined with an extremely high degree of accuracy. Figure 1 illustrates a PSLF format load flow model of the Circuit of the Future (Avanti 12 kV) and two adjacent 12 kV distribution circuits.

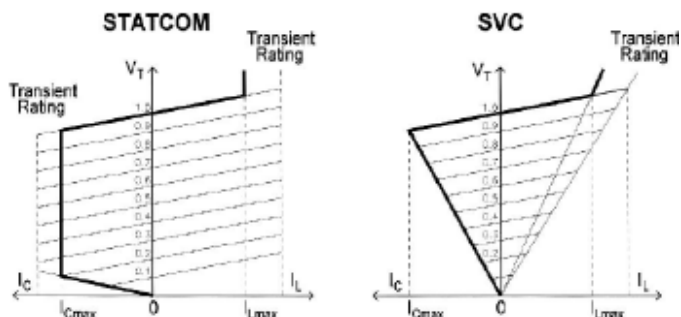

Figure 2: STATCOM and SVC Operating Characteristics

### DER, D-FACTS and Voltage Support

The Circuit of the Future project plans to include a distribution-connected Flexible AC Transmission System (FACTS) device. SCE refers to this conceptual device as D-FACTS. To begin designing specifications for the D-FACTS device, a computer-based model of the Circuit of the Future was first created using General Electric's Power Sequence Load Flow (PSLF) software as the tool for steady state analysis. Additional data was extracted from SCE's E-maps system mated with Google Earth and the proposed Circuit of the Future con-

The electrical system support characteristic desired from the D-FACTS is mitigation of infrequent temporary voltage-sags of up to -12% from nominal for up to one minute duration. This timeframe is considered sufficient to allow protective schemes to operate to clear any faults, and allow existing voltage controlled devices such as mechanically switched capacitors and transformer tap changers to participate in any ongoing steady state voltage regulation that may follow initial voltage sags. The two FACTS technologies considered by SCE for this application were Static VAR Compensator (SVC) and Static Compensator (STATCOM). For our implementation, SVC is essentially Thyristor-switched shunt caps and STATCOM is power-electronic synthesized AC from a DC bus. Figure 2 illustrates their basic operating characteristic. A significant difference between these two technologies is their relative level of correlation between bus voltage and device VAR output. An SVC's output magnitude has a strong correlation to the device's bus voltage, while the STATCOM can sustain its output magnitude relatively independent of bus voltage, down to a very low level of bus voltage.

Load flow analysis was used to provide input to the decision between using a SVC or a STATCOM based D-FACTS device for the Circuit of the Future, and to provide an indication

of the required capacity. Within the load flow model, the SVC was modeled as a shunt connected capacitor and the STATCOM was implemented as a synchronous condenser. The two proxy devices used in the load flow analysis capture the key characteristic of VAR output relative to bus voltage for each respective device. In order to determine how the devices would affect bus voltage, simulation was performed with no device installed and this was used as the baseline voltage. The initial baseline voltage was 0.91 per unit (p.u.), with an intentionally very stressed 600A peak circuit loading case. Next the amount of capacitive VAR capacity needed from each type of technology to raise the bus voltage in 2.5% intervals to 10% per unit voltage was determined. Strengthening the decision to recommend a SVC over a STATCOM device, the difference in the magnitude of capacity needed was minimal between the SVC and the STATCOM, due to the limited range of desired voltage support. Given the expected significant lower \$/KVAR cost for SVC versus STATCOM technology, and the fact that similar capacity was needed of either type technology to meet the desired performance goal, SVC was recommended for the Circuit of the Future. This has been designated the Circuit of the Future's D-SVC.

The steady-state load flow analysis showed that an SVC would be able to safely mitigate the baseline voltage up through 0.987 p.u. volts. An important observation was any mitigation above 0.987 p.u. volts caused heavy reverse VAR flow in the circuit which was injected back into the substation. This finding was a basis of setting the D-SVC maximum design capacity to 6.5 MVAR. An important conclusion yielded from this steady state study was that the planned circuit will need additional capacitance for meeting SCE's steady-state voltage criteria. SCE Tariff Rules [1] specify that steady state voltage must be no lower than -5% from nominal voltage. The D-SVC should not be used to mitigate steady state voltage. This is not the purpose of installing an SVC. In order to utilize this device to its fullest potential the Thyristor-switched elements should be used to handle temporary events, and remain ready for such events and not encumbered with performing steady state voltage regulation. The model illustrated in Figure 1 and used for additional analysis to be discussed later in the report includes the required amount of additional shunt capacitance needed for SCE to meet an acceptable level of steady-state voltage even under heavy load conditions.

With this initial input, SCE is now developing a more detailed specification for a D-SVC connection to the Circuit of the Future. Based on the load flow input, the specification includes, 1) designation of SVC-type technology, 2) maximum capacity of 6.5 MVAR, and 3) 1.2 MVAR of additional mechanically switched capacitor stages for steady state voltage control. Following Figure 3 illustrates the functionality of the proposed Circuit of the Future D-SVC.

An additional specification for the D-SVC is a requirement that the control system allow for future coordinated control of all reactive resources on the Avanti 12kV Circuit.

For this paper, additional load flow analysis was performed to demonstrate the potential to improve, i.e. flatten, the voltage

profile across the Avanti 12 kV circuit through addition of a circuit-connected generator DER asset.

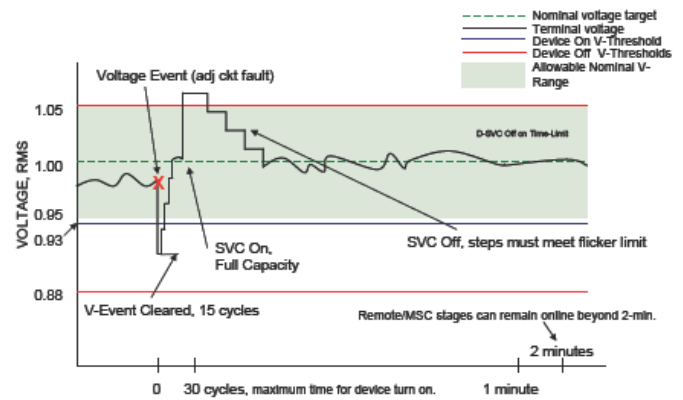

Figure 3: Functionality of the D-SVC

While the proposed D-SVC adds additional performance capability, voltage sag mitigation, there is no direct benefit during steady state conditions. SCE DER performed an earlier study that evaluated the beneficial impacts from connection of DG with VAR capability to a distribution system. The reported findings from this earlier study [2] indicated that relatively large (MW-scale) DG with VAR capability will 1) reduce circuit losses, and 2) improve a circuit's voltage profile. Using the Circuit of the Future load flow model, these earlier findings are again demonstrated in this report. Figure 1 illustrates a steady-state condition that meets SCE's basic Rule 2 requirement of maintaining steady-state bus voltages between 0.95 and 1.05 p.u.. In this initial case, without DG added, the average circuit voltages range from 0.96 – 0.99 p.u.. And the total calculated peak losses for the modeled three-circuit system is 0.77 MW. The attached Figure 4 shows the same system scenario, but with a 1 MW synchronous DG operating on the Avanti 12 kV circuit, and regulating its interconnection (12 kV) bus to 1.0 per unit. The voltages on the circuit with the DG operating had an improved range of 0.98 – 1.00 p.u.. And, the losses were reduced by -0.040 MW to 0.73 MW

Taking a very simplified approach for illustration, this incremental real power MW peak loss savings applied over an annual 8760 hours, using SCE's loss factor of 0.4<sup>1</sup>, would be,

$$0.04 \text{ MW} * 8760 \text{ hours} * 0.4 = 140 \text{ MWh.}$$

Valued at SCE's 2006 average cost of energy, 6.9 cents/kWh [3, p.17], the annual energy cost savings through loss reduction would be approximately \$4K.

This is the estimated savings from loss reduction for one distribution circuit. SCE has approximately 4,100 distribution circuits. With this number of circuits that are potential hosts for DG interconnection, the potential energy and energy-cost savings are significant, if DG participate in improving circuit voltage and reducing losses.

<sup>1</sup> SCE Loss Factor is from SCE's 2005 Transmission Expansion Report

**DER and Reconfiguration for Load Restoration**

SCE’s existing practice for post-fault circuit reconfiguration for load restoration typically utilizes three types of isolating and/or switching devices: circuit breakers at the substation sending end of the circuit, fault-interrupting-capable normally closed remote controlled automatic reclosers (RAR) at circuit mid/interior-points, and normally open remote controlled

switches (RCS) at outer-edge transfer points between circuits. In its most basic and typical implementation, this arrangement of devices allows for isolation of faulted sections through isolation of no more than 1/2 the circuit, and then recovery and restoration of load to the unfaulted remaining 1/2 of the circuit. Without this arrangement, the whole circuit and all connected load is exposed to sustained outages for major circuit faults.

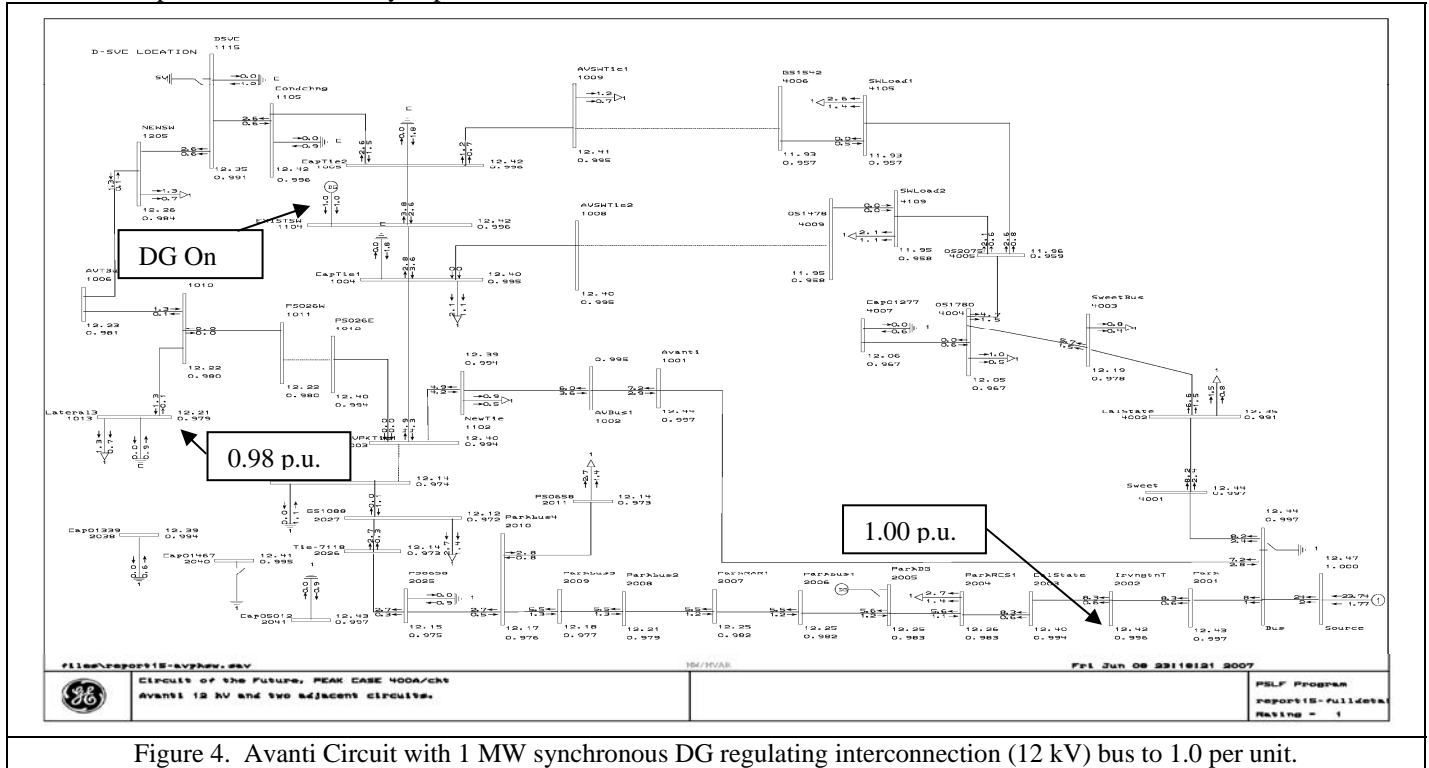

Figure 4. Avanti Circuit with 1 MW synchronous DG regulating interconnection (12 kV) bus to 1.0 per unit.

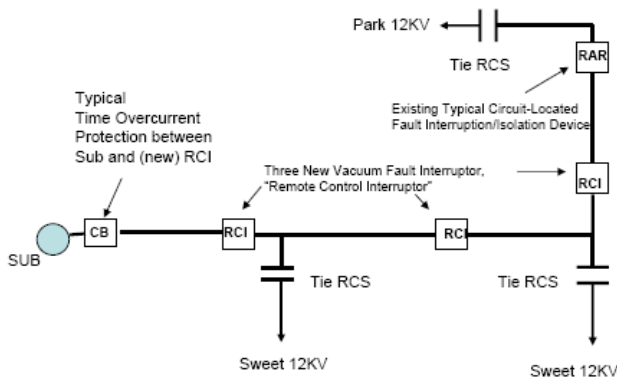

Figure 5. Planned Fault Interruptors and Switches

SCE’s Circuit of the Future will apply additional interior-circuit fault-interrupting capable devices; vacuum fault interrupter based Remote Control Interrupters (RCI). Use of multiple RCI’s deployed out on the circuit will allow for higher resolution fault isolation. In this case, the circuit will have four zones of isolation versus the more basic two. Figure 5 illustrates the planned arrangement of the various fault interrupters and switches on the Circuit of the Future.

Even assuming that only 25% of additional load would be kept online through a system-wide doubling (100% improvement)

of distribution circuit fault isolation zones, the impact to reliability based valuation metrics could still be significant. Assuming for example that doubling fault isolation results in a 25% improvement in post-fault load retention, the resulting savings could be substantial. For the following simple pair of examples, SCE’s former performance based rate reliability ‘benchmark’ value of 56 minutes (0.93 hour) system average interruption duration index (SAIDI) is used. First, based on 2006 system average statistics<sup>2</sup>, SCE’s potential lost-revenue savings assuming a 25% reduction in SAIDI is,

$$4.8 \text{ million customers} * 0.93 \text{ hours} * 2.3\text{kW} * 25\% * 11 \text{ cents/kWh} = \$286,000.$$

A more significant potential value for improved reliability is shown using an assumed customer value of service (VOS) in place of the 11 cents/kWh lost electric revenue value that was used in the calculation above. Using an assumed VOS of \$5/kWh, just for illustration purposes, the customer-side potential value from reducing the system SAIDI by 25% is,

$$4.8 \text{ million customers} * 0.93 \text{ hours} * 2.3\text{kW} * 25\% * 5 \text{ dollars/kWh} = \$51 \text{ million}.$$

<sup>2</sup> Using 2006 EIX statistics [2]: 96,146 million kWh energy sales/4.8 million customers/8760 hours = 2.3 kW avg.. SCE’s 2006 average electric service revenue was 11 cents/kWh.

This very simple pair of valuation examples shows how a broad consideration of the value of improved reliability, which considers both utility and customer value of reliability improvement, could justify performance based payment incentives for utilities to improve system service reliability. While

adding switches will increase circuit reconfiguration flexibility, the value of this increased flexibility can be enhanced and extended by use of DER as a participant in reconfiguration for load restoration. Figures 6 and 7 illustrate a load flow based example of DG support of reconfiguration.

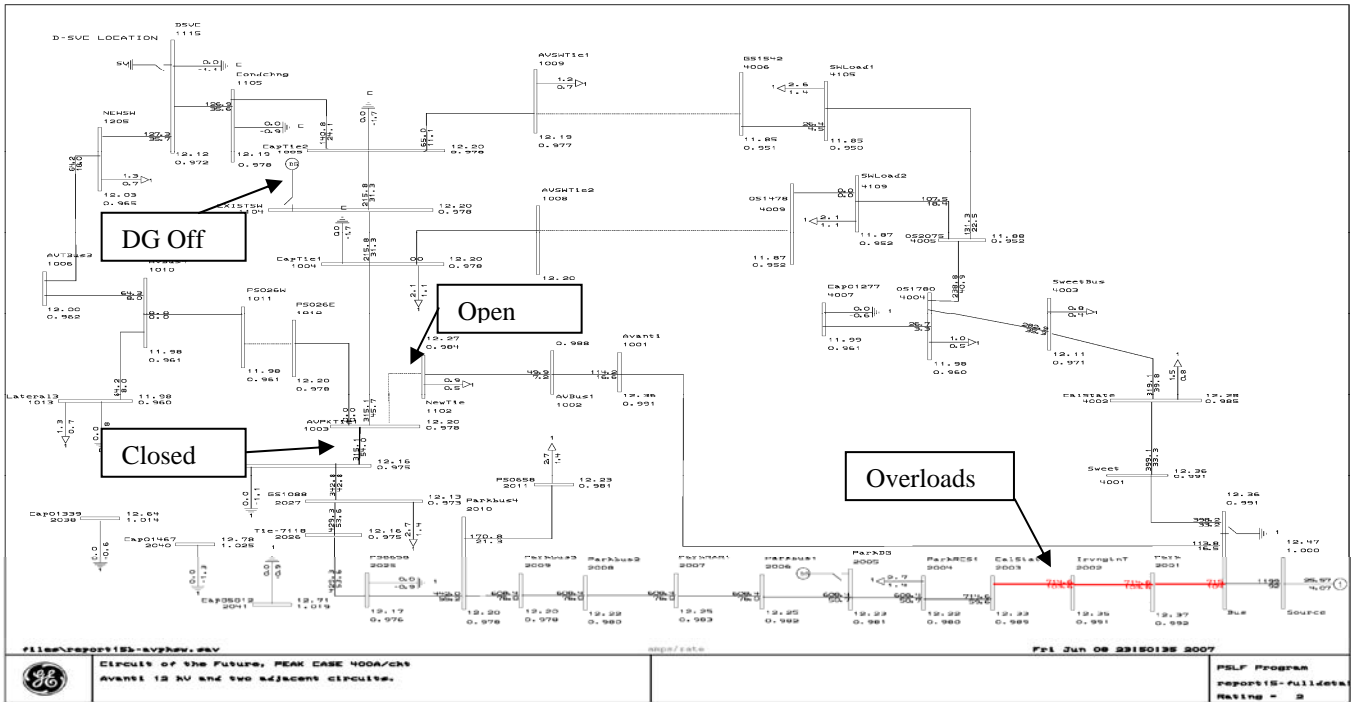

Figure 6: Overloaded Sections (red) Under Peak Load conditions<sup>3</sup>

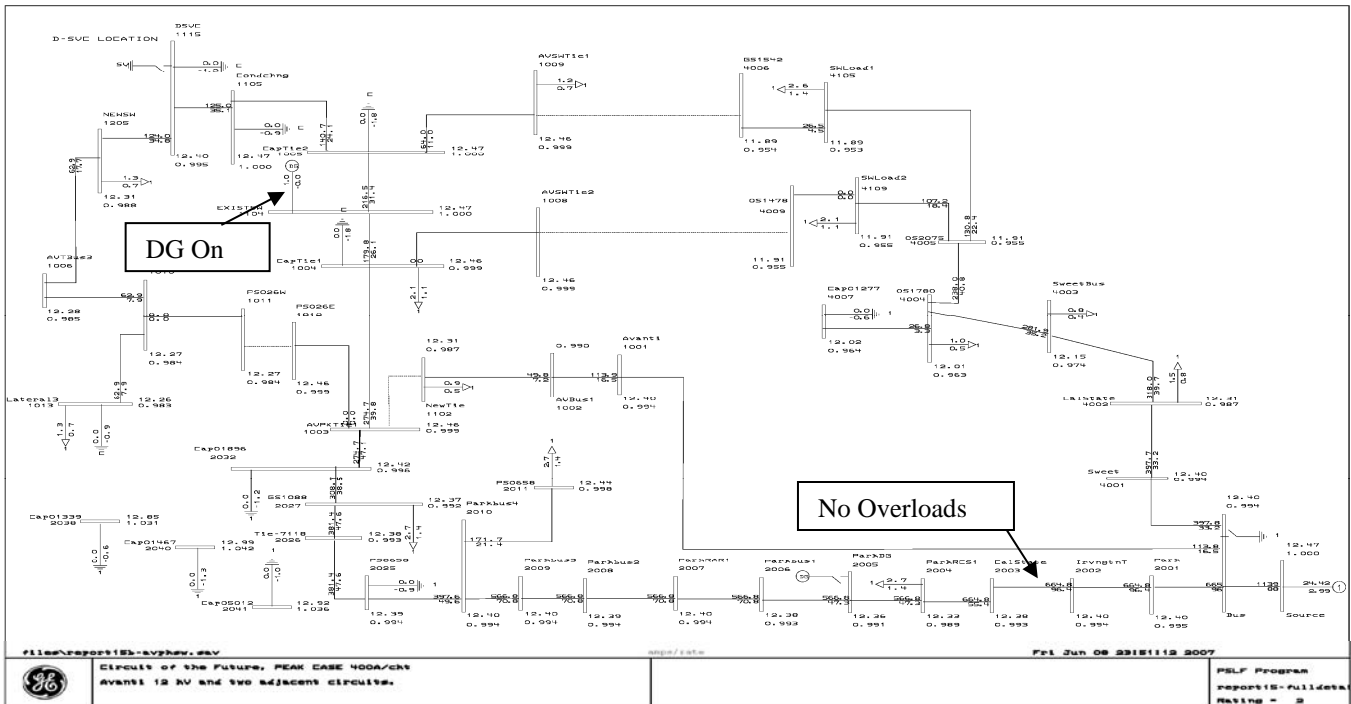

Figure 7: Overload Mitigation with a 1 MW DG put online on the Avanti 12 kV circuit.

<sup>3</sup> The units for the values shown in Fig's 6 & 7 are Amperes and percent of the circuit conductors' emergency Ampacity ratings.



## Multi-Agent Control for Distribution System Operation

With the integration of DERs, D-Facts devices and other Intelligent Electronic Devices (IEDs) in a traditional distribution system, the problem at hand becomes the coordination and the control of this complex system to achieve the objectives of improved circuit reliability, power quality and availability. The authors are addressing these issues through the development of a multi-agent system architecture that will autonomously control the smart distribution system of the future. This section describes this approach.

### *Software agents and multi-agent systems*

While there is no single accepted definition of what constitutes an “agent,” most would agree that an agent is an object that can sense and act upon its environment with some degree of autonomy. In the context of software-based agents (as opposed to biological ones) the following definition is commonly cited, “An agent is a computer system that is situated in some environment, and that is capable of autonomous action in this environment in order to meet its design objectives [4, p. 29].” This definition is fairly broad as it allows agents to occupy any environment. Also, it deliberately avoids including the term “intelligent” and leaves the necessity and ability to incorporate “intelligence,” for example through learning, to the need of the application at hand. The extension to intelligent agents can be made by designing agents that take flexible autonomous actions, where flexibility is the ability to react to the perceived environment in a timely fashion. In other words flexibility is to be pro-active through initiative-taking, goal-directed behavior, and social behavior through interactions with other agents. Though none of these three key components are difficult to implement, the challenge lies in finding a balance among them. For example, any real-time control system continuously reacts and even communicates with other parts of the system. An intelligent agent, on the other hand, may change its objective while interacting with others after realizing that its original operating objectives do not align well with some overarching goals [5].

For this project, we will refer to agents when we mean encapsulated software components that have the ability to retrieve information about their respective environments, perform computations, communicate with other agents, and autonomously act on their environment. What differentiates an agent-based concept from the object-oriented software design is that agents have autonomy. Autonomy is another concept that is difficult to define accurately but means here that agents operate without external intervention and have control over their state and behavior while acting according to their programmed objectives. In other words, agents have their own thread of execution rather than simply responding to messages and requests. Also, an agent may decline to perform services for other agents or decline to act as requested if the agent finds that such action would not be in its best interest (would not align with its objectives).

A multi-agent system is composed of a population of autonomous agents, which interact with each other to reach common objectives, while each agent simultaneously pursues individual objectives [6]. The agents help to decompose the problem into smaller entities that deploy domain (expert) knowledge.

There are many reasons to use a decentralized, agent-based design as opposed to a centralized control system. Among these are actuation speed, robustness, and overall quality of design. Agents that are co-located with actuation devices (switches, knobs, etc.) can generally collect information and act faster than centrally located controllers, as communication and processing delays tend to slow down centralized schemes. Decentralized, agent-based designs tend to be more robust to small failures, thereby increasing the overall system reliability. Finally, the combination of computational intelligence, and goal-based methods, with the decentralized agent-based control concepts can often result in designs that give better overall control results, relative to traditional controller designs.

On the other hand, it can be difficult to get autonomous agents to act in accordance with the objectives of the system as a whole. Because an agent generally operates according to a local objective function, it can act in ways that are incongruent with a set of global objectives. This is the challenge of agent-based control system design — to design the agents such that they consistently act according to the goals of the system as a whole, without limiting the agents’ autonomy too much.

Distribution systems provide an excellent test case for agent-based control. An autonomous, self-healing distribution system would have a number of advantages in terms of restoration speed and overall quality of service. A control system that was robust to single point failures, and required minimal intervention by operators would be particularly valuable during high-stress operating periods (such as a storm) as it could reduce the burden on human operators and increase restoration speed. If the distribution system could continuously optimize its voltage profile and its use of distributed generation, it may be possible to improve power quality and reduce the cost of service.

### *Control agents for smart distribution systems*

With respect to this project agents will be software processes located within industrial PC’s located near major control equipment within the distribution circuit. Each agent will have the ability to collect sensor data, including voltages, currents, frequency, and temperature from the measurement hardware that is located in the circuit. The collected data will allow the agent to observe its environment. Missing or uncertain information can be retrieved/validated through communication with other agents while each agent calculates control actions roughly according to the objectives and constraints described in the next subsection. The agents will then enact their decisions by making adjustments to control devices (switches, distributed generators, reactive power devices) in the circuit.

While ours is not the first agent-based approach to distribution system control, it has several unique properties that should lead to significant performance benefits. In [11], researchers present a conceptual, agent-based design to estimate service needs for distribution system components, identify and isolate faults, and restore service after a fault. Ref. [12] describes an agent-based design applied to the control of power output from DG units. This design has been shown to successfully facilitate load following in the test distribution system. Finally, the authors of [13, 14] describe an agent-based approach to bulk power system restoration (including the distribution system) that uses agents at each load and generator in a six substation system. The distribution network model used is fairly simple (all loads/generators are connected to a bus bar at the substation), but the method is shown to effectively solve the restoration problem. Our approach differs from the above research projects, primarily in the use of a rolling time horizon/mixed integer programming approach, and by application to the problem of voltage control, DER control and loss minimization.

### Problem formulation

The structure of the agent control problem is based upon Model Predictive Control (MPC) [7]. MPC is a control method that integrates concepts from feedback-control and model-based predictive (feed-forward) control. The controller uses a discrete time model of the system to predict how it will react to control actions and uses feedback from sensors to adjust for modeling errors. MPC is particularly useful in systems that have discrete variables, hard constraints, and objectives that include costs and benefits, as opposed to only controlling an error trajectory to zero. An MPC controller is designed by carefully describing the objectives, constraints, and control/state variables in the form of an optimization problem.

One of the distinctive features of an MPC problem is optimization over a discrete time horizon. The structure of the time-horizon for the distribution circuit problem is something that will need to be designed as this project progresses, and may need to change based upon the condition of the circuit. For example during circuit restoration after a fault, the problem will need to model enough time steps to account for each switching action, allowing enough time to collect measurements from devices, between subsequent switching actions. A time horizon with about 10 time steps spaced 10 seconds apart (100 seconds total) will probably be sufficient for most conditions. With this in mind  $t_0$  will represent the current time period, and the complete time horizon is

$$T = \{t_0 \quad t_1 \quad \dots \quad t_{|K|}\}$$

where  $K$  represents the full sequence of time step subscript variables.

At least initially, the problem will include the following control variables:

- $\mathbf{P}_G$ : a vector of active power injected into buses in the circuit by distributed energy resources and at the transmission system connection. The subscript “G” gives the set of all buses that include DER devices.

- $\mathbf{Q}_G$ : a vector of reactive power injected by DER devices, defined broadly to include controllable reactive power devices (switched capacitor banks, SVCs, etc.)
- $\mathbf{a}$ : the position of switches at each branch in the circuit.  $a_i$  is 0 when the switch is open, 1 when closed. At locations where no switch exists,  $a_i$  is always 1.
- $\mathbf{R}$ : a vector of controllable transformer tap ratios (one entry for each branch, though most will be fixed at 1). These will most likely only be located at the transmission substations, except for very large distribution circuits.

The problem will include two objectives: (O1) to minimize the cost of energy services, and (O2) to avoid/minimize unserved energy within the circuit. These two objectives will function well during the restoration phase, when the goal is to serve as much load as possible, and during normal operation, when the goal is to serve the existing load at minimum operating cost, while considering security risks to existing loads (estimated unserved energy). If we define  $\rho \in (0, 1]$ ,  $\rho^k$  is a discount factor that can be used to give some preference among control actions, O1 and O2 can be written as follows:

$$\min \sum_{k=0}^{|K|} \rho^k \sum_{i \in G} C_i(P_i) \quad (\text{O1})$$

$$\min \sum_{k=0}^K \rho^k \sum_{i \in D} P_{i,k} - E[\overline{P_{i,k}}] \quad (\text{O2})$$

In O1 above,  $C_i(P_i)$ ,  $i \in G$  is the cost of the power injection (generation) at bus  $i$ . In (O2),  $E[\overline{P_{i,k}}]$  gives the expected value of power injection due to demand at bus  $i$  given no load reduction, and  $P_{i,k}$  is the actual injection from demand. Because both values are negative, O2 measures the unserved demand for power at each time step.

The most important constraints in the problem include standard power-flow constraints (C1, C2) that relate power injections to currents and voltages, and constraints on voltage and current magnitudes (C3, C4) that allow the system to steer away from high current or off-nominal voltage conditions. Finally, one additional constraint is needed in distribution systems that are designed to operate only radially. Eq. (C5) will maintain radial circuit operation at all time.

$$I_{b,k} = a_{b,k} y_b \left( R_{b,k} V_{F(b),k} - V_{T(b),k} \right) \quad (\text{C1})$$

$$P_{i,k} + Q_{i,k} = V_{i,k} \left( \sum_{b \in B_i} I_{b,k} \right)^* \quad (\text{C2})$$

$$0.95 \leq \mathbf{V}_k \leq 1.05 \quad (\text{C3})$$

$$|I_{b,k}| \leq |I_b|_{\max} \quad (\text{C4})$$

$$\prod_{i \in L_r} a_{i,k} = 0, \quad \forall l \quad (\text{C5})$$

Each of the constraints (C1-C5) must hold for all  $k$  within the prescribed time horizon. Eq. (C1) gives the standard relationship between complex voltage and current in a power system. In (C1),  $F(b)$  and  $T(b)$  represent the set of buses on either end of branch  $b$ , i.e., from- and to-bus. Eq. (C2) gives the standard

bus injection complex power constraint. The set  $B_i$  gives the subset of all branches ( $B$ ) that are connected to bus  $i$ . It is assumed that the sign on the branch currents ( $\mathbf{I}_B$ ) are adjusted such that positive current flow is defined out of the bus. (C3-C4) give the constraints on voltage and current magnitudes, and (C5) gives the radial system constraint. In eq. (C5)  $L_i$  represents each set of branches that form a loop such that one can travel over each branch in  $L_i$  and arrive at the starting bus.

The resulting non-linear mixed integer programming problem accounts for both intentional and unintentional switching events, including capacitor bank switching, relay actions, and the control of distributed resources including reactive power resources. The problem will force the system to plan for and implement control actions that result in voltages and currents within acceptable limits, while minimizing operating costs and unserved energy. The same problem can be used during both normal operation and restoration after a fault, because during both cases the goals and constraints of the problem are roughly the same — the main difference being the initial condition of the network.

#### *Approach*

In the proposed design, one agent is placed at each switch, DG unit, and reactive power device. Each agent is given the responsibility to maintain the circuit model and chooses actions according to the mixed integer programming problem described above. The agents collect data from their neighbors and potentially from a central operator via the transmission substation using existing communications channels.

#### **Interoperability Benefits**

Interoperability, or the capability for different aspects of a circuit to work together effectively with little or no human interaction is vital to the effective use of the grid [8]. Interoperability requires components to be connected to each other using both hardware and software. Once this connection is complete, components can automatically receive data from each other and react accordingly with little to no human input.

To be implemented, interoperability has three fields that need to be addressed: technical, informational, and organizational. Technical interoperability involves the physical and communicative connectivity between actual devices. The devices must have a common protocol in order to interface with each other regardless of component brand, manufacturer, etc. Informational interoperability pertains to the content and format for data or instructions. Organizational interoperability means that the businesses involved have compatible processes and procedures. All parties must address their business, economic, and legal relationships among themselves to ensure organizational interoperability works. These three elements are all required for an effective implementation of interoperability [9]. In other words, interoperability is achieved when users can easily exchange and use information among various devices from different providers.

It must be noted that without interoperability, the benefits soon to be discussed are still possible to achieve. However, they require much more resources and human involvement. When dealing with power systems, interoperability not only has benefits to promote effective use of elements of the grid, but it also has significant economic repercussions to the parties involved.

Interoperability directly affects grid reliability by providing equipment with information about components in the grid that may or may not be working. In addition, operators can have faster access to more accurate information concerning energy flow. This information can allow for rapid response to not only help mitigate system disruptions due to natural disasters, but also correct unwanted power fluctuations that could otherwise result in outages.

Related to this would be schedule modification. If elements of a grid have the ability to communicate with each other, a change in energy production or distribution could be communicated faster to and throughout the grid to prevent energy loss or rolling blackouts. This is also an easier form of schedule modification since more automation is present.

In the event that a power outage occurs or power needs to be cut from a portion of the grid, interoperability would allow for an efficient shut down and startup procedure. Compared to the old method of “all or nothing,” interoperability would allow for a gradual shut down with less critical elements (i.e. air conditioners) shut down first and key elements shut down last (i.e. water pumps). The reverse would be true for restoring the grid following an event. In this manner, key processes would remain undisturbed for as long as possible. Similarly, gradual restoration of the grid would not only re-energize key elements first, but would also prevent a power overload due to inrush (“cold load pick-up”).

Interoperability also allows for increased customer involvement. If advanced technology is implemented successfully, customers will have access to the status of the grid at their own homes. This will allow them to remain informed and possibly help resolve undesirable energy anomalies by, for example, reducing power usage at times of high demand.

Since interoperability uses advanced technology to facilitate better monitoring and understanding of the grid, it enhances opportunities for harnessing a wide range of new resources (such as renewables) as dispersed generation.

With easier access to data, interoperability can have a direct economic benefit. Operators will be able to access real-time electricity prices and grid status which can allow them to reduce energy use when prices are high or supply is insufficient. Not only does this save consumers money, but it also lowers the costs and risks to wholesale power purchasers.

Economically, interoperability can also reduce the cost of creating and maintaining a grid. New devices leveraging information technology and containing advanced electronics will be able to complete tasks faster and for a lower cost than the elec-



tromechanical devices we have today. In addition, these new devices can be integrated and maintained much more easily than existing devices.

Interoperability is directly supported by the GridWise Architecture Council (GWAC), a team of experts sponsored by the US Department of Energy. GWAC's mission is to establish broad industry consensus regarding the integration of advanced technology and communications into electric power operations in order to enhance our socio-economic well-being and security [10].

One of the visions of GWAC is to integrate interoperability with distributed energy resources. GWAC works toward this vision by creating a framework to help identify issues and create a context that can facilitate understanding and change among those involved in the electric system. GWAC also plans to establish a consensus building process and foster cross industry segment collaboration. In this sense, GWAC acts as the "overseer" for the support and eventually the implementation of interoperability.

GWAC focuses heavily on the transformation of the power industry. Such a transformation will result from widespread adoption and use of information technology (IT) which incorporates open architecture and standards. The scope of this transformation includes the integration of new distributed technologies such as demand response, distributed generation, and storage with existing grid technology to allow for a collaborative management of the grid from power production to consumption by the ultimate customer.

### Conclusion

This paper describes the concept of improving operation of a distribution circuit of the future through installment of interoperable devices which are controlled using a multi-agent system approach. The devices that are considered for deployment include D-FACTS for voltage support, DERs, and control agents. The benefits of interoperability are presented, and a multi-agent system control architecture for distribution system operation is discussed. This concept is being considered by SCE's DER Program and its Circuit of the Future. The project team involves SCE, the Advanced Power & Electricity Research Center (APEREC) at West Virginia University and the US DoE National Energy Technology Laboratory (NETL).

### Acknowledgment

This material is based in part on work supported by the Department of Energy Office of Electricity Delivery and Energy Reliability under Award Number DE-FC26-06NT42793.

### Disclaimer

This report was prepared in part as an account of work sponsored by an agency of the United States Government. Neither the United States Government nor any agency thereof, nor any of their employees, makes any warranty, express or implied,

or assumes any legal liability or responsibility for the accuracy, completeness, or usefulness of any information, apparatus, product, or process disclosed, or represents that its use would not infringe privately owned rights. Reference herein to any specific commercial product, process, or service by trade name, trademark, manufacturer, or otherwise does not necessarily constitute or imply its endorsement, recommendation, or favoring by the United States Government or any agency thereof. The views and opinions of authors expressed herein do not necessarily state or reflect those of the United States Government or any agency thereof.

### References

- [1] SCE Tariff Rule 2: Description of Service, <http://www.sce.com/NR/sc3/tm2/pdf/Rule2.pdf>
- [2] Hamilton S, Ang A., Hennesius C., *Fuel Cells: A Utilities' Perspective*, Journal of power sources (J. power sources), 2006, vol. 158, no1, pp. 436-445
- [3] Edison Int. 2006 Financial and Statistical Report, <http://www.edison.com/files/2006EIXFinStat-a.pdf>
- [4] Gerhard Weiss, ed. *Multiagent Systems: A Modern Approach to Distributed Artificial Intelligence*, Cambridge, MA: MIT Press, 1999.
- [5] M. Wooldridge and N. R. Jennings, "Intelligent agents: Theory and Practice," *The Knowledge Engineering Review*, vol. 10, pp. 115-152. 1995.
- [6] Ferber, J., *Multi-Agent Systems: An Introduction to Distributed Artificial Intelligence*, Addison-Wesley, Harlow, UK, 1999.
- [7] E.F. Camacho and C. Bordons, *Model Predictive Control*, London: Springer-Verlag, 2003.
- [8] European Industry Association, *EICTA Interoperability White Paper*, June 2004, p. 5.
- [9] Silverstein, Alison and Schomberg, Richard. "Highlighting Interoperability." *Public Utilities*. June '07. pp 78-82.
- [10] GridWise AC website: <http://www.gridwiseac.org/>
- [11] Nordman, "An Agent Concept for Managing Electrical Distribution Networks," *IEEE Trans. Power Delivery*, 2005.
- [12] Hiyama, "Multi-Agent Based Control and Operation of Distribution System with Dispersed Power Sources," *Proceedings IEEE/PES Transmission and Distribution Conference and Exhibition 2002: Asia Pacific*, Vol. 3, pp. 2129- 2133, 2002.
- [13] Nagata, T., Y. Tahara and H. Fujita, "An agent approach to bulk power system restoration." *Proc. of the 2005 IEEE Power Engineering Society General Meeting*. vol. 1, pp. 599-604. 2005.
- [14] Nagata, T. and H. Sasaki, "A Multi-agent approach to power system restoration," *IEEE Trans. on Power Systems*, v. 17, pp. 457-462, 2002.