

Integrated, Agent-Based, Real-time Control Systems for Transmission and Distribution Networks

Paul Hines

paul.hines@sa.netl.doe.gov

National Energy Technology Laboratory

Stephanie Hamilton

Stephanie.Hamilton@sce.com

Robert Yinger

Robert.Yinger@sce.com

Charles Vartanian

Charles.Vartanian@sce.com

Southern California Edison

Ali Feliachi

alfeliachi@mail.wvu.edu

Karl Schoder

Karl.Schoder@mail.wvu.edu

Advanced Power & Electricity Research Center
West Virginia University

Keywords: Agent-based control, interoperability, special protection schemes, distribution circuit reconfiguration, distributed generation

Abstract

Centralized control systems can be easier to design and generally conform to utility industry practices, but have disadvantages in terms of actuation speed and limited robustness to failures. Interoperability among devices and across systems will facilitate decentralized decision-making systems that can react quickly to local problems and, when well designed, are more resilient to failures. This paper describes a conceptual design for the integrated, real-time control of both transmission and distribution systems. The design uses intelligent control agents located at nodes in the grid. To illustrate the utility of decentralized, agent-based, real-time control, we describe two agent-based control algorithms, one designed to mitigate the effects of cascading failures in the transmission system and the other designed to improve distribution circuit performance. After describing the proposed design concepts and presenting some example results, we describe some information technology advances that have the potential to enable an interoperable network of software agents with real-time control capabilities for both transmission and distribution.

1. INTRODUCTION

In most utility systems, the power delivery control system has two components, (1) centrally located operators (human and computerized) who schedule resources along long time horizons, and (2) decentralized protection devices that react quickly to local stress by disconnecting equipment. As information technology improves, it is possible to increase the intelligence and communications bandwidth of the decentralized devices, and decrease the reaction time of centrally managed control systems. Decentralized systems are getting smarter and centralized schemes are getting faster.

Such advances do not come too soon for the electricity industry. Open-access rules and market restructuring

generally increase demand for transmission capacity, putting more stress on the existing infrastructure. When transmission networks become overly stressed, cascading failures become ever more likely [1,2]. Some have proposed that massive investment in transmission infrastructure is needed [3], but siting new transmission lines is extremely difficult [4]. The industry will likely need to use the existing transmission infrastructure more judiciously to meet the increasing demand for long-distance power transmission. When employed correctly, information technology can help the electricity industry to use existing assets more effectively by bridging the gap between fast decentralized devices and slow centrally-located operators.

A number of technologies have been proposed to fill this gap. Many utilities operate Special Protection, or Remedial Action, Schemes (SPS or RAS) in which a control system is designed to react to extreme events by quickly enacting pre-determined sets of control actions—typically demand and generation reduction. Industry experience with SPS is mixed [5].

In addition, the architecture of the power delivery system is likely to substantively change as distributed energy resources (DER) and intermittent renewable energy sources become significant contributors to the energy supply mix. One benefit of a DER unit is the ability to supply a small section of the grid with power when the bulk power system endures a blackout. But without careful design, network reconfiguration algorithms will not reliably enable islanded operations when needed. While dynamic islanding is beneficial, DER units and other devices in a distribution circuit have the potential to provide even greater benefits to reliability and system economics when they can work cooperatively with the high-voltage system. For example, when appropriately scheduled, a DER unit can substantially reduce losses and improve the voltage profile on a circuit. In order to realize these benefits, the industry needs an agreed-upon architecture for interoperable transmission and distribution control systems.

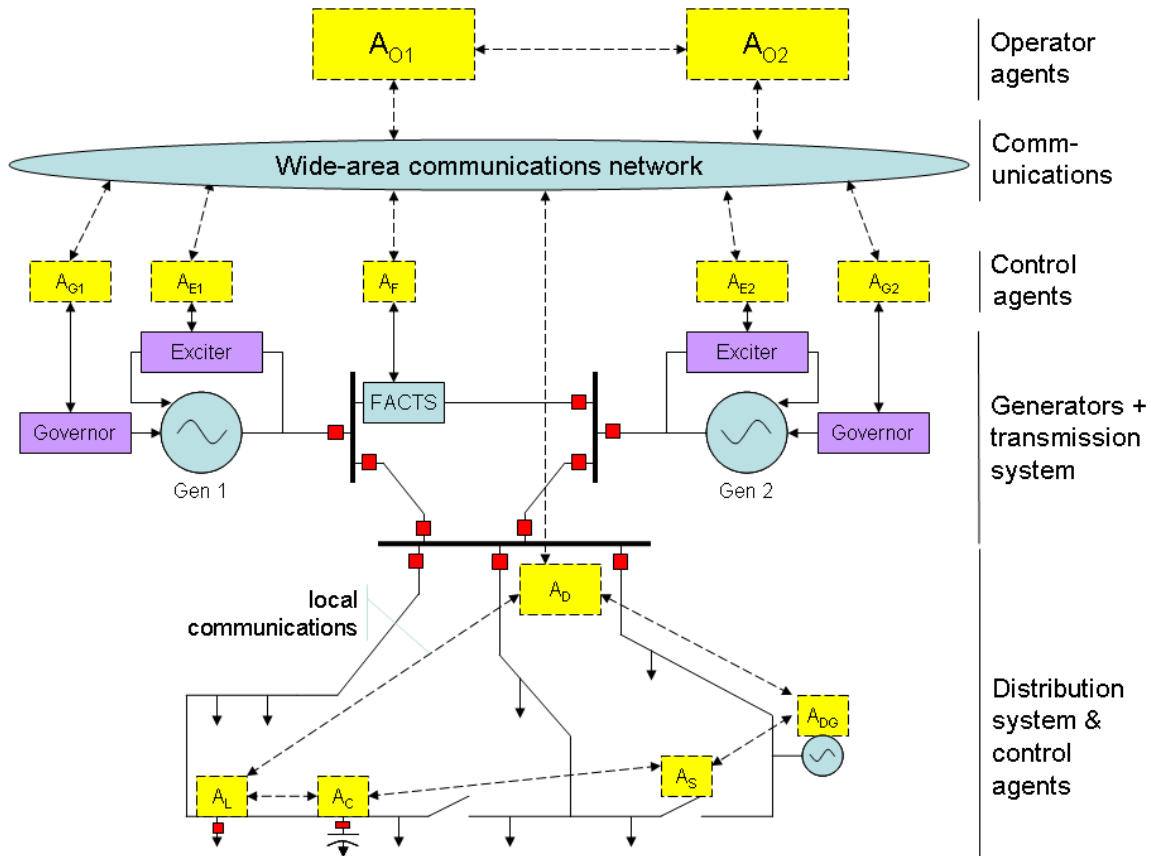

Figure 1—An illustration of the architecture for interoperable transmission and distribution control agents, as proposed in this paper. Each agent is co-located with its actuator/device. The following agents and devices are shown: A_G —generator, A_E —exciter, A_F —FACTS device, A_D —distribution substation manager-agent, A_L —load control agent, A_C —capacitor-bank, A_S —switch or interrupter, A_{DG} —distributed generator.

With these challenges in mind, this paper describes the conceptual design, and some illustrative design details, for a network of software agents with the ability to implement many real-time control tasks that require more intelligence than simple protection but are sufficiently time-critical to make a centralized implementation impractical. Section 2 describes the proposed design at a conceptual level and provides a short review of similar designs from industry and academia. Sections 3 and 4 describe illustrative designs and results for agent-based transmission and distribution control systems. Section 5 describes some of the communications infrastructure challenges associated with this design, focusing particularly on strategies for interoperability. Finally, Section 6 draws some conclusions.

2. CONCEPTUAL DESIGN

Power systems are complex large-scale interconnected systems that have a variety of actuators with different objectives and time responses. The coordination of sensors and actuators is a formidable task. Most of the existing actuators take local actions based on local information only. Such actions cannot, in general, guarantee that the devices

will act according to system-wide performance goals. However, advances in communication and computation technology can facilitate better coordination amongst the thousands of devices in a power system.

In the conceptual design illustrated in Figure 1, one control-agent is located at each actuator in both the transmission and distribution networks. Each agent is responsible to gather local measurements and choose set-points for its local device. During normal operations, when time-critical adjustments are not necessary, the agents coordinate their decisions with operator-agents, both human and computerized. When decisions must be made quickly and operator intervention is impractical, the agents work with other agents in their neighborhoods and choose actions according to agreed-upon goals and methods.

The result is a multi-layered architecture for coordinated real-time transmission and distribution system operations. Section 2.1 describes how these concepts fit with current developments at Southern California Edison (SCE). Sections 2.2-2.4 describe some additional details of the conceptual design described here.

2.1. Transmission and distribution system coordination at Southern California Edison

Traditionally, SCE has planned and operated its distribution, sub-transmission and transmission systems as relatively independent systems. Three planning/operating practices at SCE illustrate this intentional independence among system levels, reactive power (VAR) planning, radialized sub-transmission, and independent remedial action schemes (RAS). Following a brief discussion description of these practices is a discussion of several emerging practices that will require an understanding and integration of the concepts of interoperability.

2.1.1. Reactive power (VAR) planning

SCE's VAR planning standards require that no net VAR transfers take place between the transmission, subtransmission and distribution systems.

2.1.2. Radial sub-transmission

Under SCE historical practice transmission, sub-transmission (66 kV and 115 kV) and distribution systems generally operate separately—sub-systems cannot rely on one another for reactive power or other secondary support beyond maintaining a delivery chain from source to load. Few mechanisms exist for coordinating resources between these sub-systems. Consequently each sub-transmission system has a single interface with the bulk networked transmission system (220 kV and 500 kV), and each distribution circuit maintains one interface with the upstream sub-transmission system. This results in numerous radial configurations. A radial design ensures that “N-1” outages in the bulk system do not generally trigger parallel flows through the lower-voltage circuits. On the other hand, radial design generally means that more power system infrastructure is required to meet NERC/WECC requirements for serving load after “N-1” outages.

2.1.3. Independent Remedial Action Schemes (RAS)

SCE has designed its RASs so that each scheme is independent. This practice simplifies design and implementation, but may limit the potential to draw benefits from coordinated Remedial Action Schemes.

2.1.4. Future developments

The three practices described above demonstrate a conservative approach, which may limit the potential to leverage existing infrastructure for wide-area system benefit and increased efficiency. Looking forward, SCE is currently exploring other operating procedures such as: automated capacitor control schemes with a hierarchical design across voltages, a centralized RAS that could choose among systems/assets for maximum system-wide benefit and the use of locally installed resources to support system services. Furthermore, SCE initiatives closer to the consumer,

specifically SCE's SmartConnect™ advanced meter initiative, will provide additional future opportunities to expand interoperability and advanced decentralized controls schemes for system, and ultimately, customer benefit.

Improvements in and growing deployment of measurement/sensing, communications and data processing technology will facilitate opportunities to develop and deploy systems and procedures that support one another.

The concepts discussed and illustrated in this paper will inform and support these emerging efforts at SCE.

2.2. Goals

Power systems operate with many goals (objective functions to be minimized or maximized and constraints to be satisfied). Among these are economic goals, reliability goals and environmental goals. While operators can manage tradeoffs among these goals along slow time-horizons, it is the responsibility of automated control systems (control agents) to manage these when action by human operators is not practical. The following are some of the goals that are particularly important during time-critical operations:

1. Minimize the cost of serving existing load.
2. Minimize the cost of control actions (wear and tear on or damage to equipment).
3. When it is not possible to serve the entire existing load, then the goal becomes that of serving as much load as possible, perhaps weighted by relative priority among loads.
4. Maintain the system voltage profile as close as possible to an operator-defined goal profile.

During normal operations, these goals can typically be managed by human operators, with some assistance by centrally located computer systems. During stressed conditions, when delayed action could result in a massive blackout, these goals are best managed by software or hardware agents that are closer to the problems. While these goals are generally agreed to be important, setting priorities among these (and others goals not yet identified) is an important part of the design of such software systems.

2.3. Coordination methods

Many methods exist for coordinating the actions of agents. Among these are: voting schemes in which agents agree to enact the most popular action, hierarchies in which low-level agents act according to the goals of higher-level agents, and decentralized optimization methods. The algorithm described in Section 3 is based on decentralized optimization. The algorithm in Section 4, in its current form, is essentially hierarchical.

2.4. Related programs and literature

Through programs like the GridWise™ [6,7], EPRI Intelligrid [8], the CIM working group [9] and the Modern

Grid Initiative [10] the US electricity industry is making some progress on standards and designs for communications among devices in the power grid. These programs provide substantial guidance information to utilities who would like to upgrade their communications infrastructure, metering and devices. The programs provide lesser guidance for coordinating the actions of these devices to meet various control goals.

Some designs from equipment manufacturers and academia provide some guidance in this area. While a full review of existing technologies and designs is beyond the scope of this paper, [11,12] describe algorithms and conceptual designs that are in many ways related to the ideas in this paper.

3. AGENTS FOR TRANSMISSION SYSTEM EMERGENCY CONTROL

This section describes a method for coordinating emergency load shedding, governor and exciter controls to restore voltages and currents to acceptable levels before a large blackout results. High currents and low voltages often result from disturbances to the power system, such as transmission line or generator outages. When these persist, relays often act to protect equipment from damage. This can push the stress to other portions of the grid, with the result being a string of component outages known as a cascading failure. Large cascading failures, such as the Aug. 14, 2003 blackout in North America, can have enormous social costs. The method, which is described briefly here and in detail in [13], is designed to minimize these social costs associated with blackouts by quickly arresting the spread of cascading failures through load shedding and generator controls.

3.1. The global transmission control problem

The problem of minimizing the social costs of cascading failures can be written as a set of goals (objectives and constraints) that need to be met over a time horizon. More specifically, the following goals are relevant to the cascading failure problem:

1. Minimize cascading failure risk by keeping branch currents below, and voltages above, high-risk thresholds.
2. Minimize the cost of remedial control actions by enacting minimal emergency load shedding and adjustments to generator set-points (governor and exciter).

When currents or voltages are beyond their thresholds, these goals can come into conflict. In order to resolve this conflict, the above goals are re-written as a single objective Model Predictive Control (MPC) [14] problem with the following form:

$$\begin{aligned} & \text{Minimize}_{\Delta \mathbf{P}_G, \Delta \mathbf{P}_D, \Delta \mathbf{V}_G} \sum_{k=0}^{K-1} \rho^k \left(\text{Cost}(\Delta \mathbf{P}_{G,k}, \Delta \mathbf{P}_{D,k}, \Delta \mathbf{V}_{G,k}) + \text{Risk}(|\mathbf{V}_k|, |\mathbf{I}_k|) \right) \\ & \quad |\mathbf{I}_{k+1}| = |\mathbf{I}_k| + f(\Delta \mathbf{P}_{G,k}, \Delta \mathbf{P}_{D,k}, \Delta \mathbf{V}_{G,k}) \\ \text{Subject To} \quad & \quad |\mathbf{V}_{k+1}| = |\mathbf{V}_k| + g(\Delta \mathbf{P}_{G,k}, \Delta \mathbf{P}_{D,k}, \Delta \mathbf{V}_{G,k}) \\ & \quad \Delta \mathbf{P}_{G,k}, \Delta \mathbf{P}_{D,k}, \Delta \mathbf{V}_{G,k} \in \text{Feasible}_k \end{aligned}$$

where ρ^k is a discount factor for each time step in the time horizon t_0, t_1, \dots, t_K , $|\mathbf{V}|$ and $|\mathbf{I}|$ are vectors of voltage and current magnitudes, $\Delta \mathbf{P}_G$ and $\Delta \mathbf{V}_G$ are vectors of changes to the governor and exciter set points and $\Delta \mathbf{P}_D$ is the amount of demand reduction required. f and g are linear functions that translate changes to the control variables to changes in branch currents and bus voltages. The functions “Cost(...)” and “Risk(...)” evaluate the cost of emergency controls and the risk of allowing high voltages and low currents to persist. The result is a linear programming problem that can be used to calculate emergency control actions quickly, even for systems with thousands of busses. But the amount of input data required to set up the problem initially is large, requiring a full set of voltages and currents for the system at run time. Unfortunately most centrally located operators are not able to collect these data fast enough to enact such a scheme. State estimation alone can take tens of seconds to minutes. A decentralized solution, where control actions are calculated and implemented by agents located at substations, has the potential to act more quickly.

3.2. Solving the transmission control problem with agents located at substations

In the decentralized approach to the cascading failure problem, we place a control agent at each substation in a power network. Each agent is given an initial skeleton model of the power network, with all voltages at 1.0 p.u. and all currents at 0A. During normal operations, the agents talk with their neighbors to collect enough data to build rough models of the network that surrounds them. These models are fairly accurate for their immediate neighborhoods and less so for more remote locations (see Figure 2). When an agent becomes aware of a voltage or current violation, it shares the data with its neighbors and chooses a set of control actions (both local actions and estimates of what its neighbors should do) given its model of the network. It then exchanges information with agents that appear to need to take emergency controls, tries to form consensus on these emergency actions, and implements these controls. After the agents take new measurements, the process repeats until all known violations are removed (see [13] for details).

3.3. Experimental results

In order to test the method described above we created 100 large cascading failures and measured blackout sizes in each of three cases: (1) no emergency control, (2) centralized MPC with perfect information and (3) agent-based MPC. In

case (1) the cascading failures propagate through over-current relays and under-frequency load shedding. In case (2) supplementary control is provided by an omniscient agent that can measure every value in the network and control every device in the network. This provides a lower bound for cascading failure size in each case. In case (3), agents with imperfect information work to control each cascade. Figure 3 shows the distribution of cascading failure sizes for case. The MPC agents do not perform as well as an omniscient agent, but the performance reduction is small. In both cases, the average blackout size is reduced by nearly an order of magnitude relative to the base case.

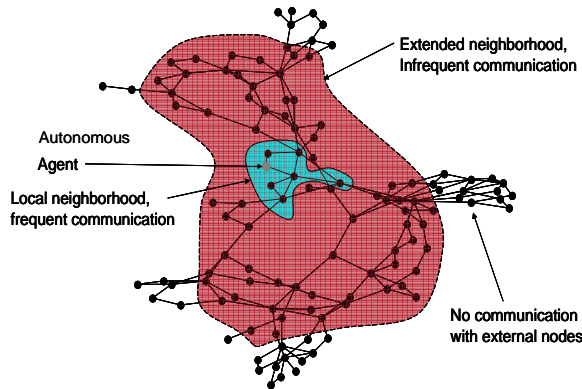

Figure 2—An illustration of one agent’s perspective of the transmission system. Each agent communicates regularly (once per second) within its local neighborhood and periodically (once per day) with extended neighbors.

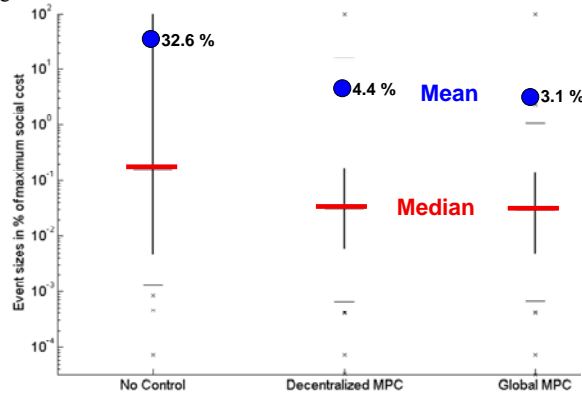

Figure 3 – The distribution of simulated cascading failure sizes without control (left), with an omniscient control agents (right) and with substation control agents (middle). While the agents, who work with imperfect information, do not perform as well as the global algorithm, the performance reduction is small.

4. DISTRIBUTION CIRCUIT CONTROL AGENTS

In our second example design, we use a network of control agents to control voltages and perform restoration within a distribution circuit. Specifically this design is based upon the following goals:

1. Ensure that voltages are as close as possible to an operator defined goal profile (typically 1.0 p.u.).

2. Keep currents below overload thresholds.
3. Serve as much of the existing demand as possible, taking into consideration possibly weighted by the relative importance of different loads.
4. Ensure that the circuit configuration is radial after control actions are complete.

The algorithm is being designed in concert with SCE’s “Circuit of the Future” program. Doing so provides a real-world distribution system for the evaluation of agent-based control methods. The controlled assets on the Avanti 12 kV circuit, relevant to this analysis include: load-break switches, load-transfer switches, load-tap transformers, mechanically switched shunt capacitors, a power electronic switched multi-stage capacitor and a distributed generator. Figure 4 illustrates the devices and systems that support the operating variables and controlled operating points in the Avanti circuit.

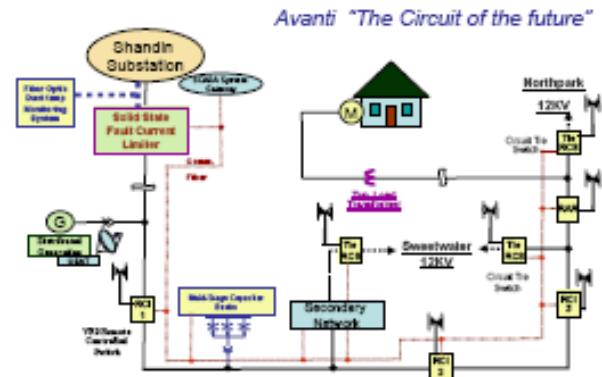

Figure 4 – Specific to interoperability, SCE’s distribution Circuit of the Future project is SCE’s effort to increase its own understanding of how to implement and leverage DER-enhanced grid interoperability as well as building the broader power industry’s understanding too.

4.1. Distribution circuit control method

To meet the distribution circuit goals, we place one agent (A_D in Figure 1) at the distribution substation for the circuit. This agent has the responsibility to collect data from other agents in the circuit and to coordinate the control actions of other agents in the circuit. Agents are also placed at each switch and DER unit in the circuit or where controllable loads are available. These agents pass data to and enact commands from A_D . When not given any commands from A_D , an agent may use simple rules based on local information to choose control actions, roughly equivalent to what is practiced currently. For example, an agent managing a switched capacitor bank (A_C) will control the bank according to the locally measured voltage, unless it gets a command from A_D to enact controls required to satisfy higher-level goals.

As with the transmission problem, A_D formulates its goals into an MPC problem. The result is the following non-

linear, mixed integer optimization problem with the following form:

$$\text{Maximize}_{\mathbf{a}, \mathbf{P}_G, \mathbf{Q}_G} \sum_{k=0}^K \rho^k \left(\mathbf{c}_D \mathbf{P}_D^T - \mathbf{c}_G \mathbf{P}_G^T - c_V \sum_i (|V_i| - |\overline{V}_i|)^2 \right) \quad (3.1)$$

$$\text{Subject To} \quad \text{PowerFlow}(\mathbf{S}_{G,k}, \mathbf{S}_{D,k}, \mathbf{V}_k, \mathbf{I}_k, \mathbf{a}) = 0 \quad (3.2)$$

$$|\mathbf{I}_k| \leq |\mathbf{I}|_{\max} \quad (3.3)$$

$$\sum_{b \in L_i} (1 - a_{b,k}) \geq 0, \forall L_i \in \text{CircuitLoops} \quad (3.4)$$

where $\mathbf{S}_D = \mathbf{P}_D + j\mathbf{Q}_D$ and $\mathbf{S}_G = \mathbf{P}_G + j\mathbf{Q}_G$ are complex vectors representing the actual demand served and the actual generator outputs, including the generation supplied by the bulk system at the transmission substation, \mathbf{a} is a vector of switch positions in the circuit, and \mathbf{c}_D , \mathbf{c}_G and c_V are cost vectors indicating the value of demand served, generator supplies and voltage profile error respectively. Eq. 3.2 represents the AC power flow equality constraints, accounting for the effects of the switch variables (\mathbf{a}). Eq. 3.3 gives the current limits in the circuit, and Eq. 3.4 enforces the constraint that the circuit must be radial at the final time period. When solved, the problem outputs a sequence of control actions (changes to switches and generators primarily) that are feasible and meet the circuit's goals. After calculating a control plan in this way, A_D will send commands to the switch and DER agents to enact the controls.

Clearly, this hierarchical approach is fairly simple, and relies on the correct operation of A_D to a large extent. In future work, we will study more sophisticated approaches to coordinating the agents' control actions.

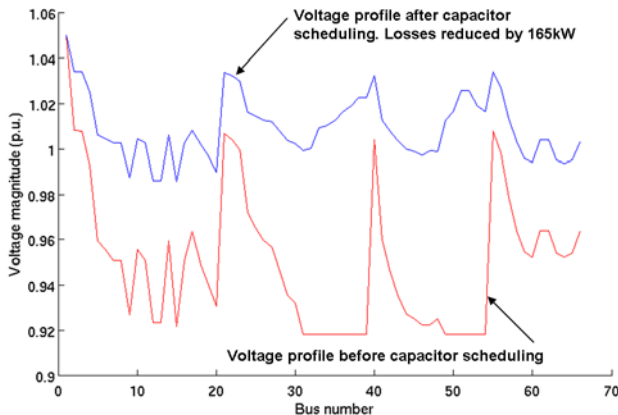

Figure 5—The voltage profile in the SCE circuit, with 24 MW of demand, before and after capacitor switching according to the problem formulation in Eqs. 3.1-3.4.

4.2. Example results from capacitor scheduling

To illustrate the utility of this problem formulation, Figure 5 shows the voltage profile of the SCE circuit before and after scheduling the switched shunt capacitors in the circuit according to the problem formulation described above. By including both the voltage profile and loss minimization in

the objective function, we were able to make significant improvements in both dimensions of the problem through appropriate capacitor switching. In future work we will extend these results to the reconfiguration problem, refine the algorithm and work on ways to decompose these two problems among the substation agent and agents located at the actuators (switches, capacitors, etc.).

5. INTEROPERABILITY

If the electricity industry is to achieve the vision of integrated, coordinated transmission and distribution systems control, it will need to develop standards that allow agents in the network to communicate clearly and efficiently. In the computer and software industries, substantial progress has been made in this area through the design of open standards for storing and sharing information. Such “Open Systems” are designed to avoid any proprietary interfaces and protocols, adhering instead to open standards. Several standards for data exchange among devices at the substation level and for SCADA applications have emerged in recent years. The following is a brief discussion of some of these.

5.1. Standards for power system communications

The growing number of intelligent electronic devices within substations and electric distribution and transmission systems has prompted several efforts aimed at developing open communications protocols for T&D equipment [15]. The IEC 61850 standard [16] defines a model for intra-substation communications for both real-time and non real-time communication and incorporates ideas developed within the Utility Communication Architecture (UCA, [17]) 2.0 efforts. The IEC 60870-5 series defines a protocol for substation to control center communication and has specific extensions for use over wide-area networks. The Distributed Network Protocol (DNP, [18,19]) is another communications protocol for both intra-substation and substation to central/utility and is based in part on the IEC 60870-5 series. All of these standards were developed to unify the many protocols used by T&D and automation equipment vendors.

In addition to protocols for the exchange of data, agents need standards to ensure that the data itself is clearly defined. Most current data-description standards are based upon XML (extensible markup language) standards. One XML project for T&D data is based on the Common Information Model (CIM, [9]) through IEC Technical Committee 57. CIM allows abstracting and representing all major power system objects needed for power flow topology models, energy management systems, and data management systems, and is a continuation of EPRI's Control Center API (CCAPI) efforts. Standards for distribution system data, within CIM, are still in progress.

Work is also being conducted to unify the IEC 61850 object models with those associated with CIM.

Additional work is being done under the UCA International Users Group in the area of standards for automated metering and demand response. This users group has subgroups covering IEC 61850, CIM and OpenAMI. As more utilities start to implement advanced metering systems that incorporate customer demand response, monitoring and control can be exercised down to the specific customer level. Capabilities are being developed that would allow 2-way communications all the way from the utility to the customer. This would include a link to the customer thermostat to allow control of thermostats.

Outside of the power-systems arena, the Foundation for Intelligent Physical Agents (FIPA, [20]), an IEEE Computer Society Standards Organization, has established standards for both agent design and communications protocols. FIPA provides a general framework for agent communication languages (ACL). The work here will extend the vocabulary and ontology in the FIPA standards by building on concepts and terminology established by CIM. Once the ACL components have been defined, other agents with different design goals can be easily integrated into the resulting multi-agent system, facilitating interoperability through and open design.

5.1.1. The limits of current technology and data-exchange practices

While the ideal communications system would allow peer-to-peer communications between any two system components, in reality most utility communications systems only allow this communication to take place at the system “head-end” or central database. Most utilities have different communications systems for each type of automation (transmission SCADA, substation automation, distribution automation, load control, meter reading). Given current technology, if a smart agent needs data from more than one system, it would have to get it from the system’s central databases. This communication structure might limit the capabilities of agents that need to act quickly to using only data from within one communications system. Communications requiring more detailed data from other central databases would need to be obtained in a slower manner and used to establish local operation goals for the agents.

5.2. Benefits of interoperability

Interoperability, or the capability of different components of a circuit to work together effectively with little or no human interaction, is vital to the effective use of the grid [21]. Interoperability requires components to be connected to each other using both hardware and software. Once this

connection is complete, components can interact with little to no human input.

To be implemented, interoperability has three fields that need to be addressed: technical, informational, and organizational.

Technical interoperability involves the physical and communicative connectivity between actual devices. The devices must have a common protocol in order to interface with each other regardless of component brand, manufacturer, etc. Informational interoperability pertains to the content and format for data or instructions. Organizational interoperability means that the businesses involved have compatible processes and procedures. All parties must address their business, economic, and legal relationships among themselves to ensure organizational interoperability works. These three elements are all required for an effective implementation of interoperability [22]. In other words, interoperability is achieved when users can easily exchange and use information among various devices from different providers.

The GridWise Architecture Council (GWAC) provides a forum and framework that will help the electric utility industry achieve interoperability. GWAC’s mission is to establish broad industry consensus regarding the integration of advanced technology and communications into electric power operations in order to enhance our socio-economic well-being and security [23]. SCE DER’s participation on GWAC provides us direct input and exposure to this exciting area of industry advancement.

SCE DER believes that many aspects of the GWAC vision are in direct alignment, not just with SCE DER’s interests and needs, but with SCE and wider industry interests. The following highlights particular areas of the GWAC vision that we embrace.

GWAC’s vision is to integrate interoperability with distributed energy resources. GWAC works toward this vision by establishing a framework to help identify issues and create a context that can facilitate understanding and change among those involved in the electric system. GWAC also plans to establish a consensus building process and foster cross industry segment collaboration. In this sense, GWAC acts as the “overseer” for the support and eventually the implementation of interoperability.

GWAC focuses heavily on the transformation of the power industry. Such a transformation will result from widespread adoption and use of information technology (IT) which incorporates open architecture and standards. The scope of this transformation includes the integration of new distributed technologies such as demand response, distributed generation, and storage with existing grid technology to allow for a collaborative management of the

grid from power production to consumption by the ultimate customer.

We support GWAC's plan to establish a consensus building process and foster cross industry segment collaboration. In this sense, GWAC acts as the "overseer" for the support and eventually the implementation of interoperability.

Given all the technical promise from interoperability, it increases the need to address other non-technical critical factors such as benefit/cost, regulated criteria/constraints, and lack of market mechanisms to provide incentives for innovation. These factors remain open as challenges to be addressed, if the industry is to actually realize the technical potential illustrated in our paper.

6. CONCLUSIONS

Advances in information technology have the potential to facilitate substantial improvements in T&D real-time operations. It is increasingly possible for the components of the T&D system to solve very difficult problems in real time, without needing to consult centrally located control centers. An agent-based design for coordinated real-time T&D control could bridge the gap between simple devices, such as relays, that use only local information to make quick decisions, and operator-based controls that require a lot of information and act along longer time horizons. While the concepts and results described in this paper are far from complete, they hopefully provide some guidance for the industry as it develops plans for future real-time control methods. Before any of this technology can be implemented, the industry needs widely agreed upon standards for data and communications protocols—for interoperability.

References

- [1] H. Liao, J. Apt, and S. Talukdar, "Phase Transitions in the Probability of Cascading Failures," *Proc. of the First Annual Carnegie Mellon Conf. on the Electricity Industry*, 2004.
- [2] B.A. Carreras, V.E. Lynch, I. Dobson, D.E. Newman, "Critical points and transitions in an electric power transmission model for cascading failure blackouts," *Chaos*, v. 12, n. 4, pp. 985-994, 2002.
- [3] E. Hirst and B. Kirby, "Expanding Transmission Capacity: A Proposed Planning Process," *The Electricity Journal*, v.15, n.8, pp. 54-59, 2002.
- [4] S. P. Vajjhala and P.S. Fischbeck, "Quantifying siting difficulty: A case study of US transmission line siting." *Energy Policy*, v. 35, n. 1, pp. 650-671, 2007.
- [5] P. M. Anderson and B. K. LeReverend, "Industry experience with special protection schemes," *IEEE Transactions on Power Systems*, v. 11, n. 3, pp. 1166-1176, 1996.
- [6] "GridWise: Rethinking Energy from Generation to Consumption," online: <http://www.gridwise.org/>.
- [7] "Gridwise Architecture Council," online: <http://www.gridwiseac.org/>.
- [8] Electric Power Research Institute, "IntelliGrid Architecture," online: <http://intelligrid.info/>.
- [9] Common Information Models (CIM) XML. See online: <http://www.langdale.com.au/CIMXML/>.
- [10] National Energy Technology Center, "The Modern Grid Initiative," online: <http://www.netl.doe.gov/moderngrid/>.
- [11] H. Li, G. Rosenwald, J. Jung, and C. C. Liu, "Strategic Power Infrastructure Defense," *Proc. of the IEEE*, v. 93, pp. 918-933, 2005.
- [12] J. Bertsch, C. Carnal, D. Karlson, J. McDaniel and K. Vu, "Wide-area protection and power system utilization," *Proc. of the IEEE*, v. 93, n. 5, pp. 997-1003, 2005.
- [13] P. Hines, "A decentralized approach to reducing the social costs of cascading failures," Ph.D. thesis: Carnegie Mellon University, 2007.
- [14] J. Rawlings, "Tutorial Overview of Model Predictive Control," *IEEE Control Systems Magazine*, v. 20, n. 3, pp. 38-52, 2000.
- [15] J. McDonald, *Electric Power Substations Engineering*, CRC Press, Boca Raton, 2003.
- [16] International Electrotechnical Commission, online: <http://www.iec.ch/>.
- [17] UCA International Users Group, online: <http://www.ucausersgroup.org/>.
- [18] Distributed Network Protocol, online: <http://www.dnp.org/>.
- [19] *IEEE Recommended Practice for Data Communications Between Remote Terminal Units and Intelligent Electronic Devices in a Substation*, IEEE Std. 1379-2000, 2001.
- [20] The Foundation for Intelligent Physical Agents, online: <http://www.fipa.org/>.
- [21] European Industry Association, *EICTA Interoperability White Paper*, June 2004, p. 5.
- [22] A. Silverstein and R. Schomberg, "Highlighting Interoperability," *Public Utilities Fortnightly*, v. 145, n. 6, pp. 78-82, 2007.

Acknowledgements

This technical effort was performed in support of the National Energy Technology Laboratory's on-going research in energy delivery and reliability under the RDS contract DE-AC26-04NT41817 and the Department of Energy's Office of Electricity Delivery and Energy Reliability under Award Number DE-FC26-06NT42793. The method described in Section 3 was developed in the course of research sponsored by ABB Corporate Research and directed by Prof. Sarosh Talukdar, as part of the Carnegie Mellon University Electricity Industry Center.

Disclaimer

This report was prepared in part as an account of work sponsored by an agency of the United States Government. Neither the United States Government nor any agency thereof, nor any of their employees, makes any warranty, express or implied, or assumes any legal liability or responsibility for the accuracy, completeness, or usefulness of any information, apparatus, product, or process disclosed, or represents that its use would not infringe privately owned rights. Reference herein to any specific commercial product, process, or service by trade name, trademark, manufacturer, or otherwise does not necessarily constitute or imply its endorsement, recommendation, or favoring by the United States Government or any agency thereof. The views and opinions of authors expressed herein do not necessarily state or reflect those of the United States Government or any agency thereof.

Biographies

Paul Hines is a research scientist with SAIC, working at the US DOE National Energy Technology Laboratory (NETL). Paul received a Ph.D. from Carnegie Mellon University in Engineering & Public Policy in 2007, a MS from the University of Washington in 2001 and a BS from Seattle Pacific University, both in Electrical Engineering. Before coming to NETL, Paul worked for the Federal Energy Regulatory Commission, where he studied interactions between nuclear power plants and the transmission network, Alstom ESCA, where he designed a short-term load forecasting tool, and for Black and Veatch, where he worked on various substation design projects.

Stephanie Hamilton is in charge of Distributed Energy Resources for SCE. At SCE, Ms. Hamilton oversees a diverse portfolio R&D of new and emerging DER technologies, such as concentrating solar, fuel cells, microturbines and balance of plant components such as inverters. Previously Ms. Hamilton held energy positions at some of the largest utilities in the US in both natural gas and power in both their regulated and unregulated subsidiaries,

including Southern California Gas, Public Service New Mexico, and Grant County PUD. Ms. Hamilton holds an MBA and a BS in Mechanical Engineering and is widely published on energy and energy-related issues. Her latest book is The Handbook of Microturbine Generators. Meanwhile, she is an original member of DOE's 13-member GridWise Architecture Council which is focused on increasing interoperability in the North American power industry.

Robert Yinger is a Consulting Engineer in SCE's Engineering Advancement Group. In his 30 years with SCE, Bob has been involved in a wide range of research and development activities including subtransmission planning, solar and wind energy development, power quality, peer-to-peer radio development, electronic metering systems, and substation automation. His present work includes investigation of the effects of air conditioner stalling on system voltage, advanced metering, and new automation technologies for substations and the distribution system. Bob received his BSEE from California State University, Long Beach. He is a licensed Professional Engineer in California and a member of IEEE.

Charles Vartanian is Project Manager for DER Development at SCE's Distributed Energy Resources group (DER). Charlie is the primary technical liaison for the group supporting joint technical research studies with external entities. These studies are actively evaluating how to best integrate and leverage DER assets for future utility grid benefit. Before this assignment, Charlie worked for SCE's Transmission & Interconnection Planning group. Charlie received his MSEE from USC, and his BSEE from Cal Poly Pomona. Charlie is a licensed Professional Engineer in California, and is a member of the IEEE.

Ali Feliachi is the holder of the endowed Electric Power Systems Chair in the Department of Computer Science & Electrical Engineering and the Director of the Advanced Power & Electricity Research Center at West Virginia University. He obtained MS and PhD degrees in Electrical Engineering from Georgia Tech. Following graduation he held a postdoctoral position at Georgia Tech and was a consultant to Georgia Power. His research interests are control, modeling and simulation of electric power systems.

Karl Schoder is a research assistant professor at the Advanced Power and Electricity Research Center (APERC) at West Virginia University (WVU). Karl received a Ph.D. from West Virginia University in Electrical Engineering in 2002, and a Diplom-Ing. degree (MS) in Electrical Engineering, Automation and Control, from the University of Technology, Vienna, Austria, in 1997. His research topics include modeling, simulation, and control of electric power systems with a focus on agent-based autonomous controls and reconfiguration schemes.